

# ZBS 16-30/83-170S-2MA/MRA/Solar

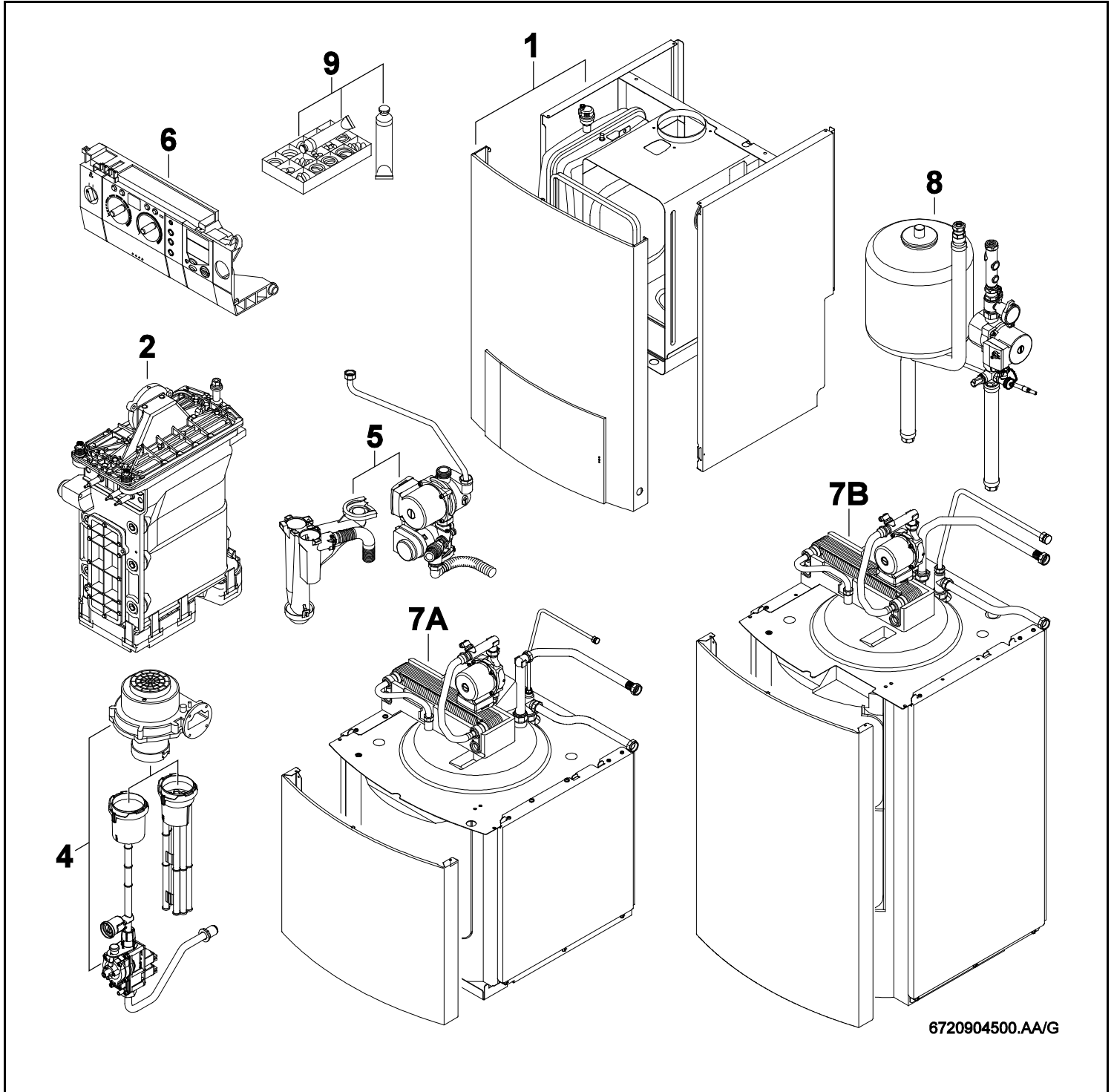

6720904500.AA/G



**[de] Wichtige Hinweise zur Installation/Montage**

Die Installation/Montage muss durch eine für die Arbeiten zugelassene Fachkraft unter Beachtung der geltenden Vorschriften erfolgen.

**[en] Important notes on installation/assembly**

The installation/assembly must be carried out by a professional who is authorised to do the work, and with due regard to the relevant regulations.

**[fr] Instructions importantes pour l'installation/le montage**

L'installation/le montage doit être effectué(e) par un spécialiste qualifié pour les opérations concernées et dans le respect des prescriptions applicables.

**[bg] Важни указания във връзка с инсталацията/монтажа**

Инсталацията/монтажът трябва да се извършва от лицензиран за работите специалист в съответствие с приложимите разпоредби.

**[cs] Důležité pokyny k instalaci/montáži**

Instalaci/montáž musí při dodržení platných předpisů provést odborný pracovník s příslušným oprávněním pro tyto práce.

**[da] Vigtige anvisninger til installationen/monteringen**

Installationen/monteringen skal foretages af en godkendt installatør under overholdelse af de gældende forskrifter.

**[el] Σημαντικές υποδείξεις για την εγκατάσταση/συναρμολόγηση**

Η εγκατάσταση/συναρμολόγηση πρέπει να πραγματοποιείται από εξουσιοδοτημένο για τις εργασίες αυτές τεχνικό προσωπικό, το οποίο θα πρέπει να φροντίζει ώστε να τηρούνται οι ισχύουσες διατάξεις.

**[es] Indicaciones importantes para instalación/montaje**

La instalación/el montaje lo debe realizar personal especializado autorizado para los trabajos, respetando las prescripciones vigentes.

**[et] Olulised juhised paigaldamiseks/montaažiks**

Paigaldamist/montaaži tohib läbi viia selleks volitusi omav spetsialist, arvestades kehtivaid nõudeid.

**[fi] Belangrijke aanwijzingen betreffende de installatie/montage**

De installatie/montage moet worden uitgevoerd door een voor de werkzaamheden geautoriseerde installateur. Hij moet rekening houden met de geldende voorschriften.

**[fi] Tärkeitä asennus- ja kokoonpano-ohjeita**

Näihin töihin hyväksytyn ammattiasentajan pitää suorittaa asennus- ja kokoonpanotyöt voimassa olevien määräysten mukaisesti.

**[hu] Fontos tudnivalók az installáláshoz/szereléshez**

Az installálást/szerelést egy, a munkákra felhatalmazott szakembernek kell végeznie, az érvényes előírások figyelembevételével.

**[it] Avvertenze importanti per l'installazione/il montaggio**

L'installazione/il montaggio deve aver luogo ad opera di una ditta specializzata ed autorizzata in osservanza delle disposizioni vigenti.

**[he] מניפולציות חיוניות לביצוע התקנת/הרכבת המכשיר**

התקנת/הרכבת המכשיר חייבת להיעשות על ידי מומחה מוסמך, המעריך את המצב ומבטיח את ביצוע התקנת/הרכבת המכשיר בצורה נכונה.

**[lt] Svarbios instaliavimo ir (arba) montavimo nuorodos**

Instaliuoti ir montuoti, laikantis galiojančių taisyklių, leidžiama kvalifikuotiems specialistams, kurie buvo įgalioti šioms darbams atlikti.

**[lv] Svarīgi norādījumi par iekārtas uzstādīšanu / montāžu**

Iekārtas uzstādīšanu/montāžu ir jāveic specializētam sertificētam speciālistam, ievērojot spēkā esošos noteikumus.

**[nl] Belangrijke aanwijzingen betreffende de installatie/montage**

De installatie/montage moet worden uitgevoerd door een voor de werkzaamheden geautoriseerde installateur rekening houdend met de geldende voorschriften.

**[no] Viktig informasjon om installasjon/montering**

Installasjonen/monteringen skal gjennomføres av autoriserte installatører, og gjeldende forskrifter skal følges.

**[pl] Ważne wskazówki dotyczące instalacji/montażu**

Instalacja/montaż muszą być wykonane przez uprawnionego do tego rodzaju prac specjalistę przy zachowaniu obowiązujących przepisów.

**[pt] Indicações importantes relativas à instalação/montagem**

A instalação/montagem deve ser efetuada por um técnico especializado com qualificações para estes trabalhos, tendo em atenção os regulamentos em vigor.

**[ro] Indicații importante privind instalarea/montajul**

Instalarea/montajul trebuie realizate de către un specialist autorizat pentru lucrările respective, respectându-se prescripțiile valabile.

**[ru] Важные указания по подключению/монтажу**

Подключение/монтаж должны выполнять специалисты, имеющие допуск к выполнению таких работ, при соблюдении действующих норм и правил.

**[sk] Dôležité pokyny týkajúce sa inštalácie/montáže**

Inštaláciu/montáž musí realizovať odborník s oprávnením na výkon týchto prác, pričom musí dodržiavať platné predpisy.

**[sl] Pomembni napotki za nameštitev/montažo**

Nameštitev/montažo mora izvesti strokovnjak, pristojen za tovrstna dela, ob upošte vanju veljavnih predpisov.

**[sr] Važna uputstva za ugradnju i montažu**

Ugradnju i montažu moraju da obave samo stručna lica ovlašćena za izvođenje takvih radova koja će poštovati važeće propise.

**[sv] Viktiga anvisningar för installation/montering**

Installationen/monteringen måste utföras av en behörig och fackkunnig person enligt gällande föreskrifter.

**[tr] Kurulum/Montaj ile ilgili önemli uyarılar**

Kurulum/Montaj çalışmaları sadece yetkili bayiler tarafından aşağıda belirtilen talimatlar dikkate alınarak yapılmalıdır.

**[uk] Важливі вказівки щодо установки/монтажу**

Установку/монтаж мають здійснювати фахівці, що мають дозвіл на проведення цих робіт, із дотримання чинних приписів.

**[zh] 安装方面的重要提示**

必须由受到许可承担该项工作的专业人员遵照相关法规进行安装。

**[ar] ملاحظات هامة للتركيب/التجميع**

يجب أن يتم التركيب/التجميع من قبل متخصص مصرح له بالعمل، مع مراعاة اللوائح السارية.

**[fa] تکرار مهم درباره نصب/مونتاژ**

نصب/مونتاژ باید توسط فردی حرفه ای که مجاز به انجام این کار است، و همچنین با توجه کامل به مقررات مربوطه انجام شود.

Spare parts list  
Ersatzteilliste

Liste des pièces de rechange  
Lista parti di ricambio

Onderdelenlijst

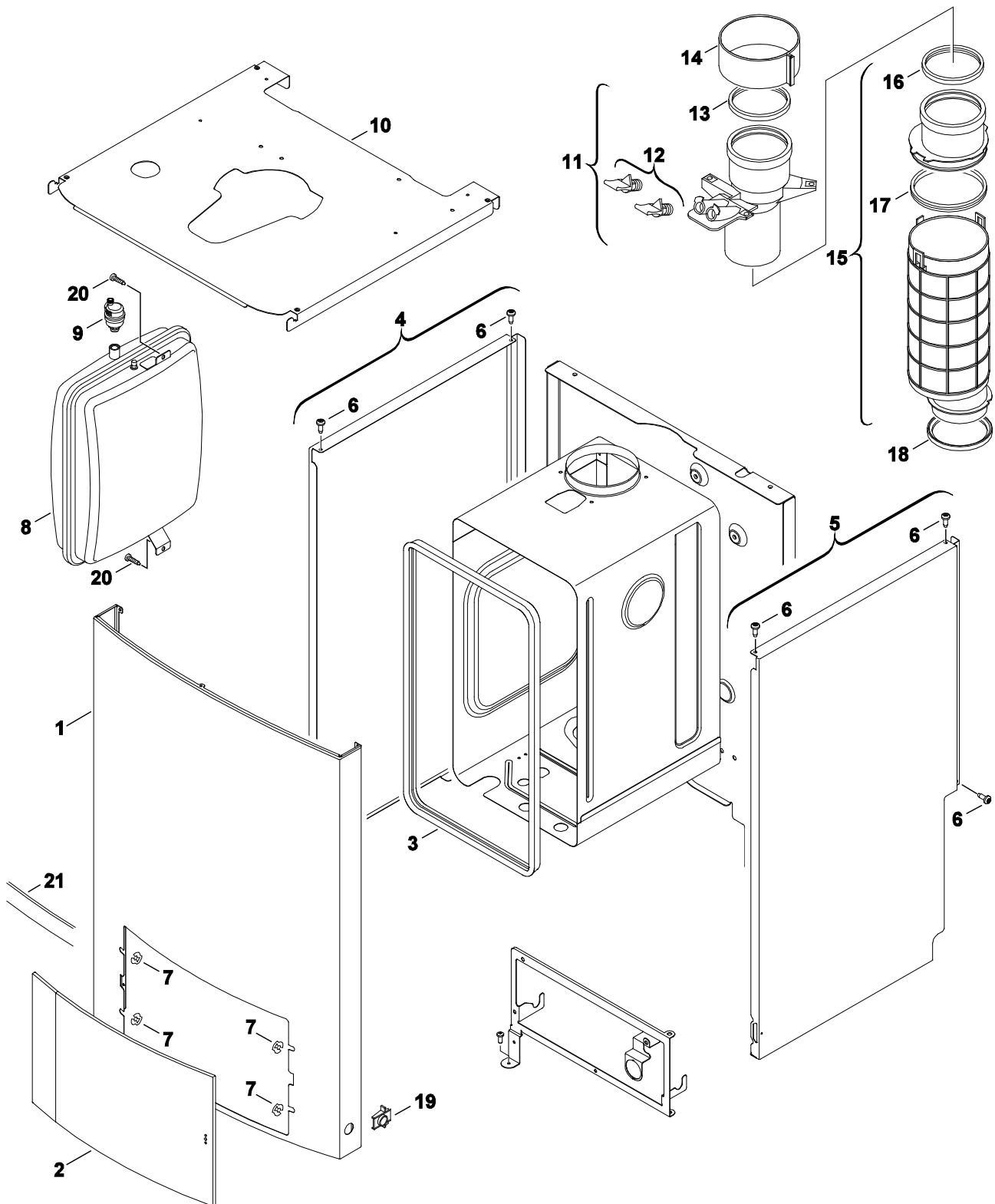

6720904501.AB/G

**1**

Sheet metal  
Blechteile  
Pièces de tôle  
Parti di lamiera  
Mantel

ZBS 16-30/83-170S-2MA/MRA/Solar



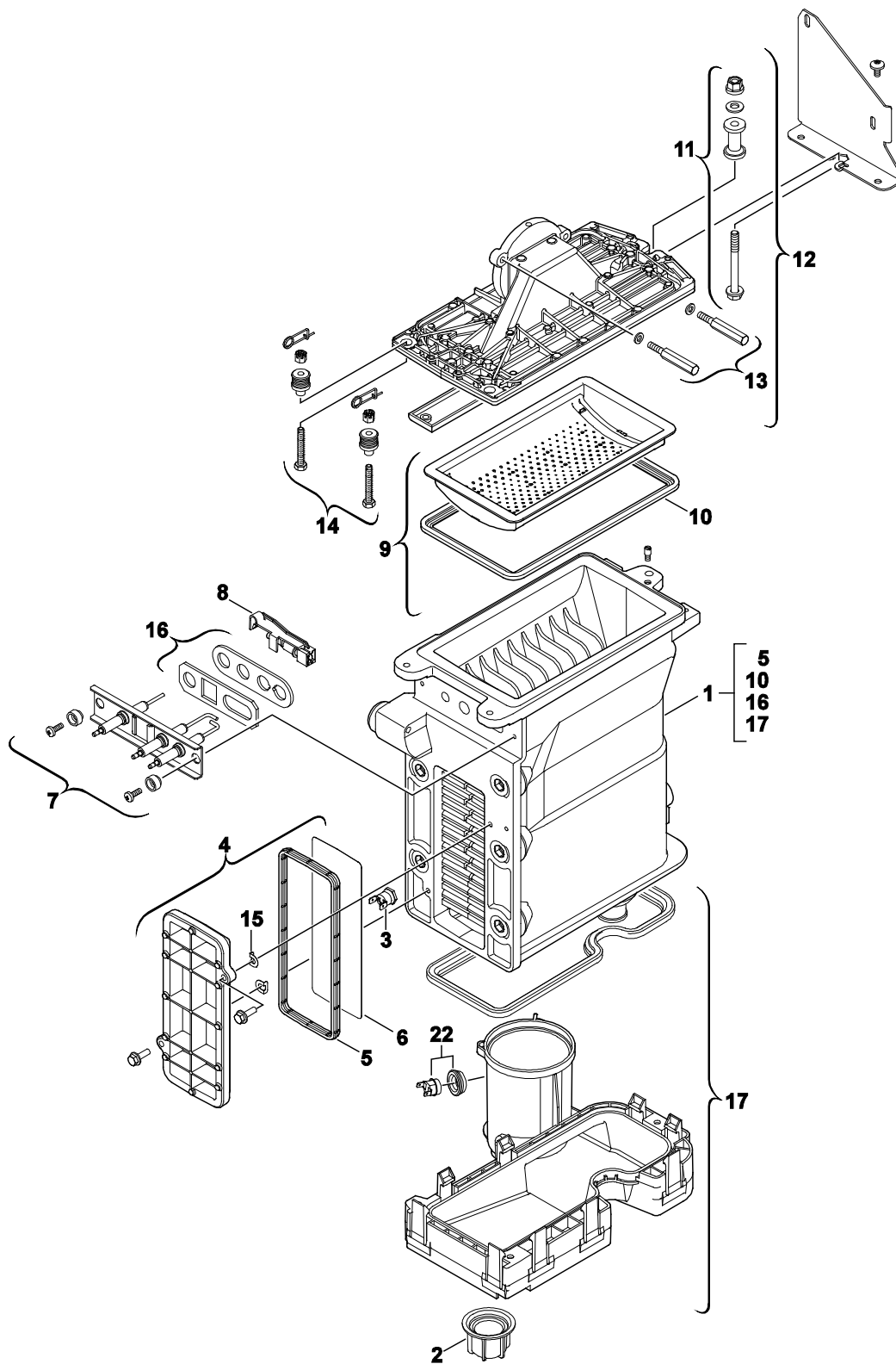

6720901536.AD/G

**2**

Burner/Heat exchanger  
Brenner/Wärmeübertrager  
Brûleur/Caloporteur  
Bruciatore/Blocco lamellare  
Brander/Warmtewisselaar

ZBS 16-30/83-170S-2MA/MRA/Solar



Spare parts list  
Ersatzteilliste

Liste des pièces de rechange  
Lista parti di ricambio

Onderdelenlijst

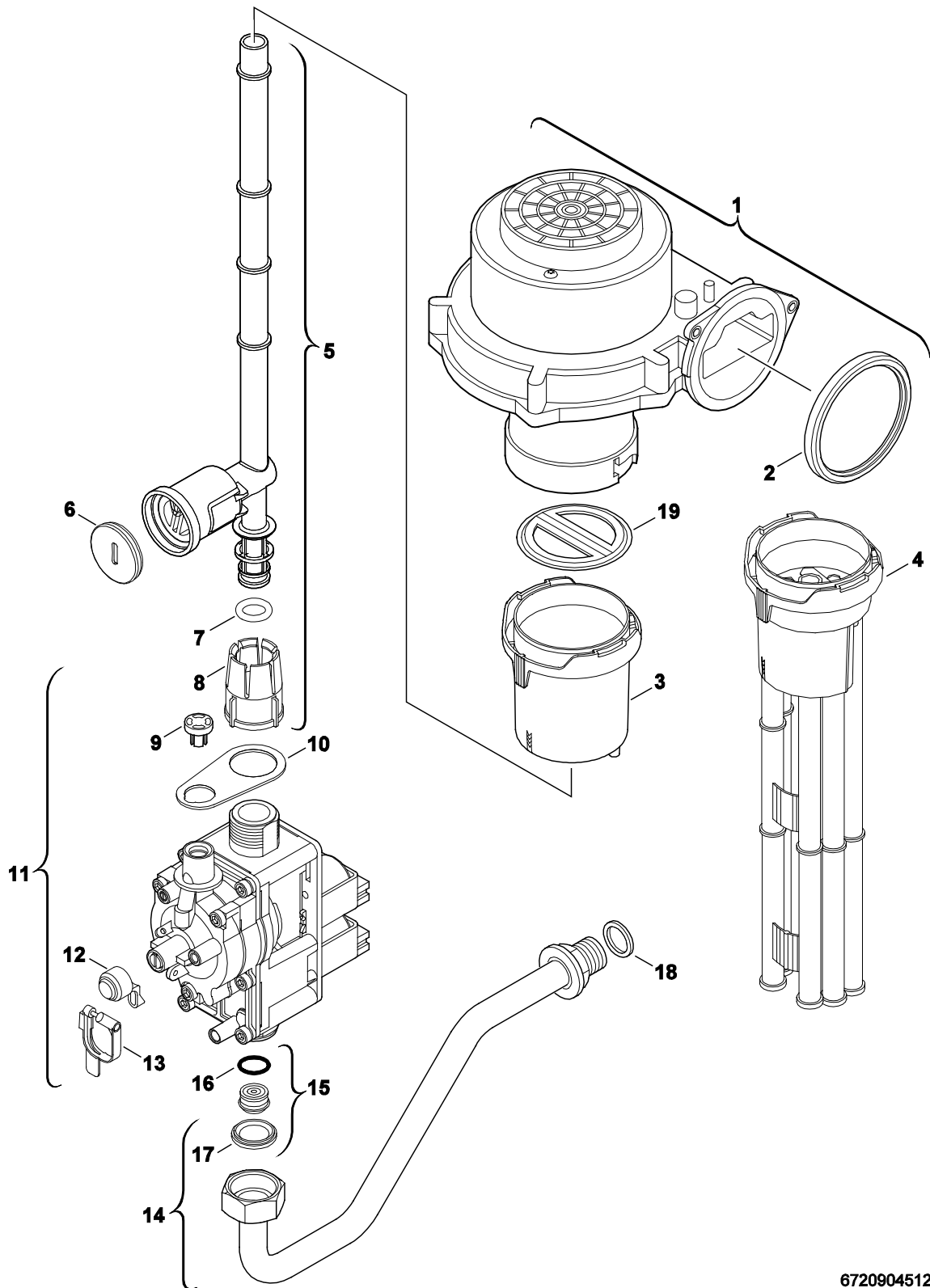

6720904512.AA/G

**4**

Gas valve  
Gasarmatur  
Bloc gaz  
Gruppo gas  
Gasregelblok

ZBS 16-30/83-170S-2MA/MRA/Solar

Pos	Description Bezeichnung Dénomination Descrizioni Benaming	S-Nr	Ordering no. Bestell-Nr. Numéro de commande N° d'ordine Bestelnummer	PG	TOP 30/260-2	TOP 30/375-2	TOP 30/400-2 SOLAR	TURBO TOWER 30 HRC	TURBO TOWER 30 HRC S	ZBS16/83S-2MA	ZBS16/83S-2MRA	ZBS16/120S-2MA	ZBS16/150S-2MA	ZBS16/170S-2solarMA	ZBS16/170S-solarMA	ZBS22/83S-2MA	ZBS22/120S-2MA	ZBS22/120S-2MRA	ZBS22/150S-2MA	ZBS30/83S-2MA	ZBS30/150S-2MA	ZBS30/170S-2solarMA	Remarks Bemerkungen Remarques Osservazioni Opmerkingen	
1	Centrifugal blower	0404,0800,1400,5000,5200,5300,7	8 717 204 343 0	53																				
1	Fan assembly	0404,0700,0800,1400,3600,5000,5	8 717 204 373 0	53	■	■	■	■	■							■	■	■	■	■	■	■	■	
2	Washer		8 729 000 183 0	13	■	■	■	■	■							■	■	■	■	■	■	■	■	
3	Mixer	0800,1400,5000,5200,5300,7200	8 711 000 260 0	19						■	■	■	■	■										
3	Air limiter	3600	8 711 000 282 0	30	■	■	■																	
4	Air limiter	0404,0700,0800,1400,5000,5200,5	8 711 000 257 0	21				■	■							■	■	■	■	■	■	■	■	
4	Mixer	0404,0800,5300	8 711 000 260 0	19						■					■	■								
5	Pipe - gas	0404,0700,0800,1400,3600,5000,5	8 710 725 500 0	23	■	■	■	■	■							■	■	■	■	■	■	■	■	
5	Gas pipe	0404,0800,1400,5000,5200,5300,7	8 710 725 502 0	24						■	■	■	■	■	■									
6	Lead seal		8 712 305 092 0	15	■	■	■	■	■	■	■	■	■	■	■	■	■	■	■	■	■	■	■	
7	O-ring 12x3 (10x)		8 710 205 089 0	11	■	■	■	■	■	■	■	■	■	■	■	■	■	■	■	■	■	■	■	
8	Unit Union		8 713 301 117 0	09	■	■	■	■	■	■	■	■	■	■	■	■	■	■	■	■	■	■	■	
9	Protective cap		8 715 503 344 0	12	■	■	■	■	■	■	■	■	■	■	■	■	■	■	■	■	■	■	■	
10	Washer		8 710 103 165 0	05	■	■	■	■	■	■	■	■	■	■	■	■	■	■	■	■	■	■	■	
11	Gas valve ce427	0404,0800,1400,5000,5200,5300,6	8 747 003 508 0	52						■	■	■	■	■	■	■						■		
11	Gas valve ce427	0404,0700,0800,1400,3600,6100	8 747 003 773 0	52	■	■	■	■	■	■	■	■	■	■	■	■	■	■	■	■	■	■	■	
12	Protective cap		8 710 506 117 0	15	■	■	■	■	■	■	■	■	■	■	■	■	■	■	■	■	■	■	■	
13	Lead seal		8 712 305 023 0	15	■	■	■	■	■	■	■	■	■	■	■	■	■	■	■	■	■	■	■	
14	Gas supply pipe		8 710 735 205 0	38	■	■	■	■	■	■	■	■	■	■	■	■	■	■	■	■	■	■	■	
15	Throttle bush (38)		8 710 303 073 0	24																				
15	Throttle bush (27)		8 710 303 074 0	24							■													
16	O-ring	0700	8 710 205 062 0	11				■			■													
17	Sealing washer 23.9 X 17.2 X 1.5 (10x)		8 710 103 043 0	12	■	■	■	■	■	■	■	■	■	■	■	■	■	■	■	■	■	■	■	
18	Washer 18.6 X 13.5 X 1.5 (10x)		8 710 103 045 0	11	■	■	■	■	■	■	■	■	■	■	■	■	■	■	■	■	■	■	■	
19	bearing plate	0404,0700,0800,3600,5000,5200,5	8 715 505 801 0	19	■	■	■	■	■	■	■	■	■	■	■	■								
	Gas conversion set 21,23>31	0700,1400,5000	7 710 149 033	27				■	■							■	■	■	■					
	Gas conversion set 21,23>31	1400,5000	7 710 149 035	26						■	■		■	■										
	Gas conversion set 31>21,23	0700,1400,5000	7 710 239 072	23				■	■							■	■	■	■					
	Gas conversion set 31>21,23	1400,5000	7 710 239 073	20						■	■		■	■										
	Gas conversion kit 21,23>31	0404,5000,6100	8 719 001 041 0	31																			■	■
	Gas conversion kit 31>21,23	0404,5000,6100	8 719 001 042 0	25																			■	■
	Gas conversion set	5300	8 719 001 072 0	27						■														
	Gas conversion set	5300	8 719 001 073 0	25												■								
	Gas conversion set	5300	8 719 001 074 0	28																			■	
<b>ZBS 16-30/83-170S-2MA/MRA/Solar</b>										Gas valve Gasarmatur Bloc gaz Gruppo gas Gasregelblok												<b>4</b>		

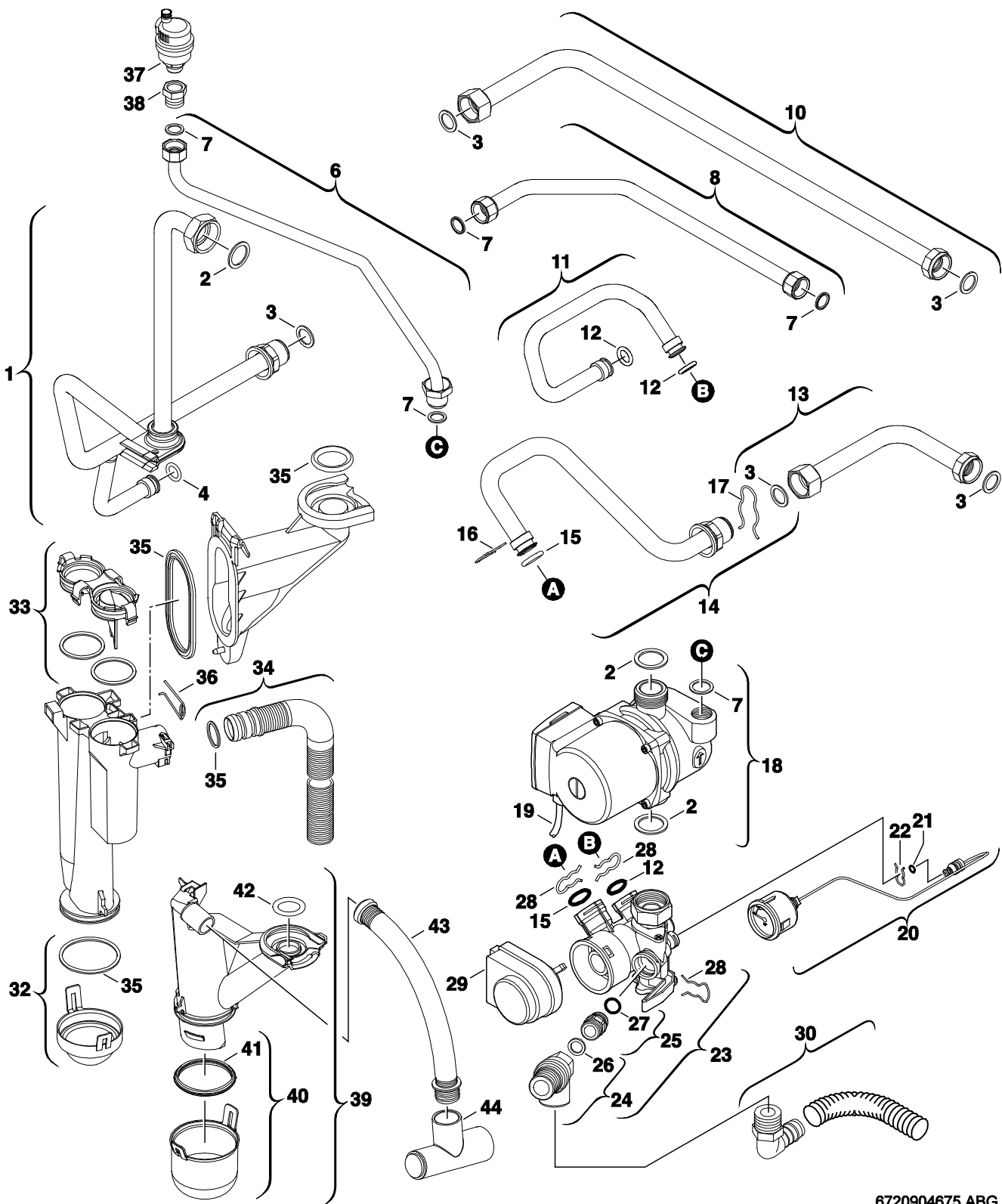

6720904675.ABG

5

Pump/Tubes  
Pumpe/Rohre  
Pompe/Tubes  
Pompa/Raccordi  
Pomp/Pijps

ZBS 16-30/83-170S-2MA/MRA/Solar



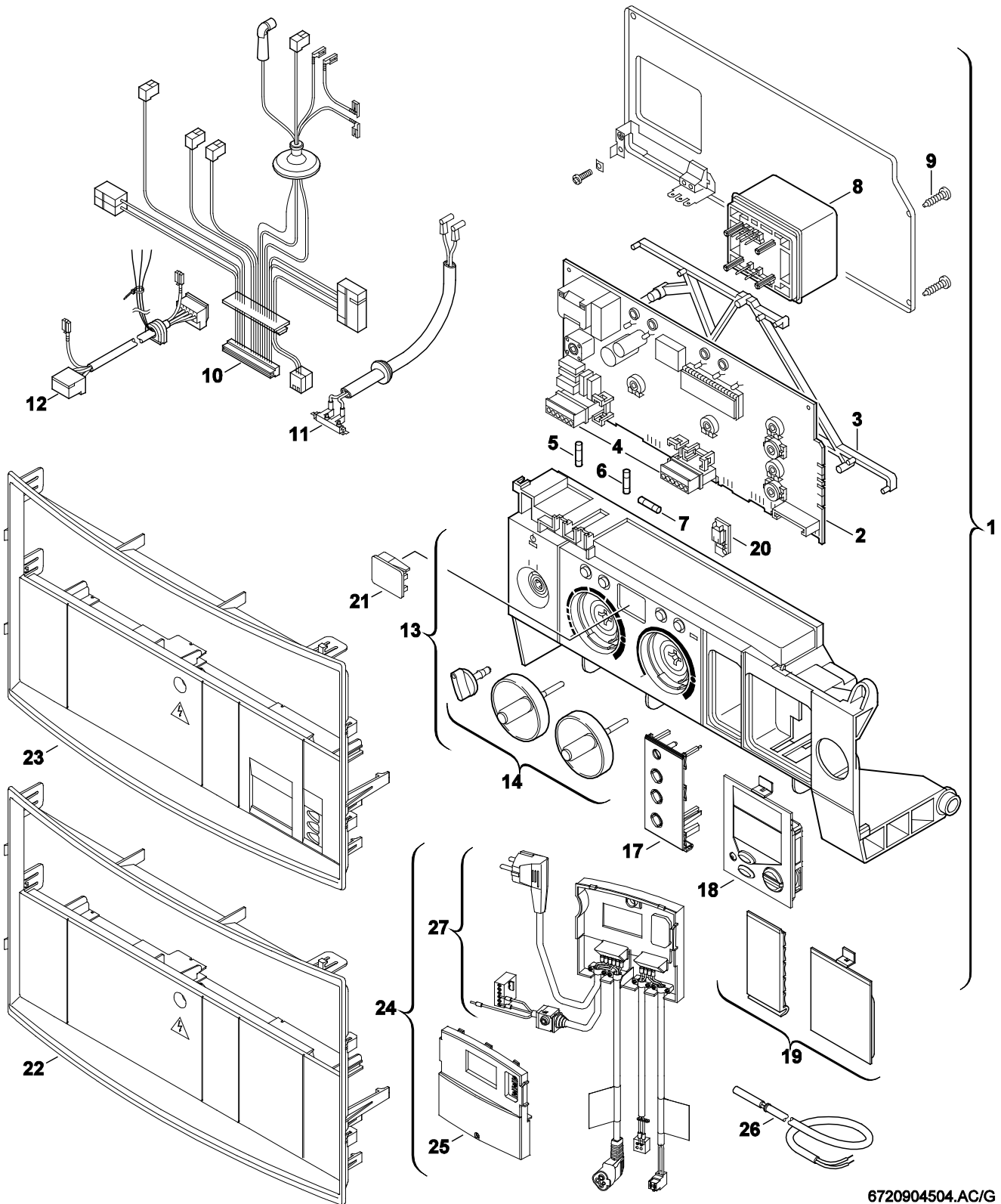

6720904504.AC/G

**6**

Control box  
Schaltkasten  
Tableau de commande  
Quadro comandi  
Schakelkast

ZBS 16-30/83-170S-2MA/MRA/Solar

Pos	Description Bezeichnung Dénomination Descrizioni Benaming	S-Nr	Ordering no. Bestell-Nr. Numéro de commande N° d'ordine Bestelnummer	PG	TOP 30/260-2	TOP 30/375-2	TOP 30/400-2 SOLAR	TURBO TOWER 30 HRC	TURBO TOWER 30 HRC S	ZBS16/83S-2MA	ZBS16/83S-2MRA	ZBS16/120S-2MA	ZBS16/150S-2MA	ZBS16/170S-2solarMA	ZBS16/170S-solarMA	ZBS22/83S-2MA	ZBS22/120S-2MA	ZBS22/120S-2MRA	ZBS22/150S-2MA	ZBS22/150S-2MRA	ZBS30/83S-2MA	ZBS30/150S-2MA	ZBS30/170S-2solarMA	Remarks Bemerkungen Remarques Osservazioni Opmerkingen
1	Control unit	0404,0800,1400,3600,5000,5200,5	8 717 207 636 0	53	■	■	■			■	■	■	■	■	■	■	■	■	■	■	■	■	■	
1	Control unit		8 717 207 645 0	57							■								■					
1	Control unit	0404,5000,5200,5300,6000,6100,7	8 717 207 650 0	51																	■	■	■	
1	Control unit	0700	8 717 207 743 0	53				■	■															
2	Printed circuit	0404,3600,5000,5200,5300,6000,6	8 748 300 498 0	51	■	■	■															■	■	■
2	Printed circuit	0404,0800,1400,5000,5200,5300,6	8 748 300 512 0	53						■	■	■	■	■	■	■	■	■	■	■	■			
2	Printed circuit	0700	8 748 300 547 0	49				■	■															
3	Spacer		8 711 503 197 0	22	■	■	■	■	■	■	■	■	■	■	■	■	■	■	■	■	■	■	■	■
4	Set of plugs		8 714 404 226 0	22	■	■	■	■	■	■	■	■	■	■	■	■	■	■	■	■	■	■	■	■
5	Fusing element T2,5A (10x)		1 904 521 342 0	20	■	■	■	■	■	■	■	■	■	■	■	■	■	■	■	■	■	■	■	■
6	Fusing element T0,5A (10x)		1 904 522 730 0	15	■	■	■	■	■	■	■	■	■	■	■	■	■	■	■	■	■	■	■	■
7	Fusing element T1,6A (10x)		1 904 522 740 0	15	■	■	■	■	■	■	■	■	■	■	■	■	■	■	■	■	■	■	■	■
8	Transformer		8 747 201 358 0	32	■	■	■	■	■	■	■	■	■	■	■	■	■	■	■	■	■	■	■	■
9	Screw (10x)		8 713 403 013 0	12	■	■	■	■	■	■	■	■	■	■	■	■	■	■	■	■	■	■	■	■
10	Set of cables		8 714 402 086 0	36	■	■	■	■	■	■	■	■	■	■	■	■	■	■	■	■	■	■	■	■
11	Ignition lead		8 714 401 999 0	31	■	■	■	■	■	■	■	■	■	■	■	■	■	■	■	■	■	■	■	■
12	Pump cable		8 714 411 321 0	29	■	■	■	■	■	■	■	■	■	■	■	■	■	■	■	■	■	■	■	■
13	Casing light grey		8 717 207 478 0	39	■	■	■	■	■	■	■	■	■	■	■	■	■	■	■	■	■	■	■	■
14	Rotary handles light grey		8 712 000 104 0	25	■	■	■	■	■	■	■	■	■	■	■	■	■	■	■	■	■	■	■	■
17	TA211E/C1		8 747 207 187 0	55							■									■				
18	GREENSTAR DIGITAL TIMER		7 719 002 016								■									■				
19	Shield light grey	0404,0700,0800,1400,3600,5000,5	8 711 000 276 0	14	■	■	■	■	■	■		■	■	■	■	■	■	■	■	■	■	■	■	■
20	Code plug 1012	0800,1400,5000,5200,5300,6100,7	8 714 411 012 0	17								■								■				
20	CODE PLUG	3600	8 714 411 050 0	14	■	■	■																	
20	Code plug	0404,0700,5000,5200,5300,6000,6	8 714 430 427 0	15				■	■													■	■	■
21	Observation window		8 715 506 166 0	10	■	■	■	■	■	■	■	■	■	■	■	■	■	■	■	■	■	■	■	■
22	Shield	0404,0700,0800,1400,3600,5000,5	8 715 503 566 0	30	■	■		■		■	■	■				■	■	■	■	■	■	■	■	
23	Shield	0404,0700,0800,3600,5300,6100	8 715 503 567 0	30			■	■						■	■								■	
24	Controller	0404,0700,0800,3600,5300,6100	8 715 402 473 0	53			■	■						■	■								■	
25	Covering sheet	0404,0700,0800,3600,5300,6100	8 715 503 565 0	30			■	■						■	■								■	
26	Temperature sensor	0404,0700,0800,3600,5300,6100	7 739 300 062				■	■						■	■								■	
27	Cable	0404,0700,0800,3600,5300,6100	8 714 402 129 0	40			■	■						■	■								■	
	Fusing element set T0,5/t1,6/t2,5/t3,15A		8 744 503 010 0	11	■	■	■	■	■	■	■	■	■	■	■	■	■	■	■	■	■	■	■	■
<b>ZBS 16-30/83-170S-2MA/MRA/Solar</b>										Control box Schaltkasten Tableau de commande Quadro comandi Schakelkast													<b>6</b>	

Spare parts list  
Ersatzteilliste

Liste des pièces de rechange  
Lista parti di ricambio

Onderdelenlijst

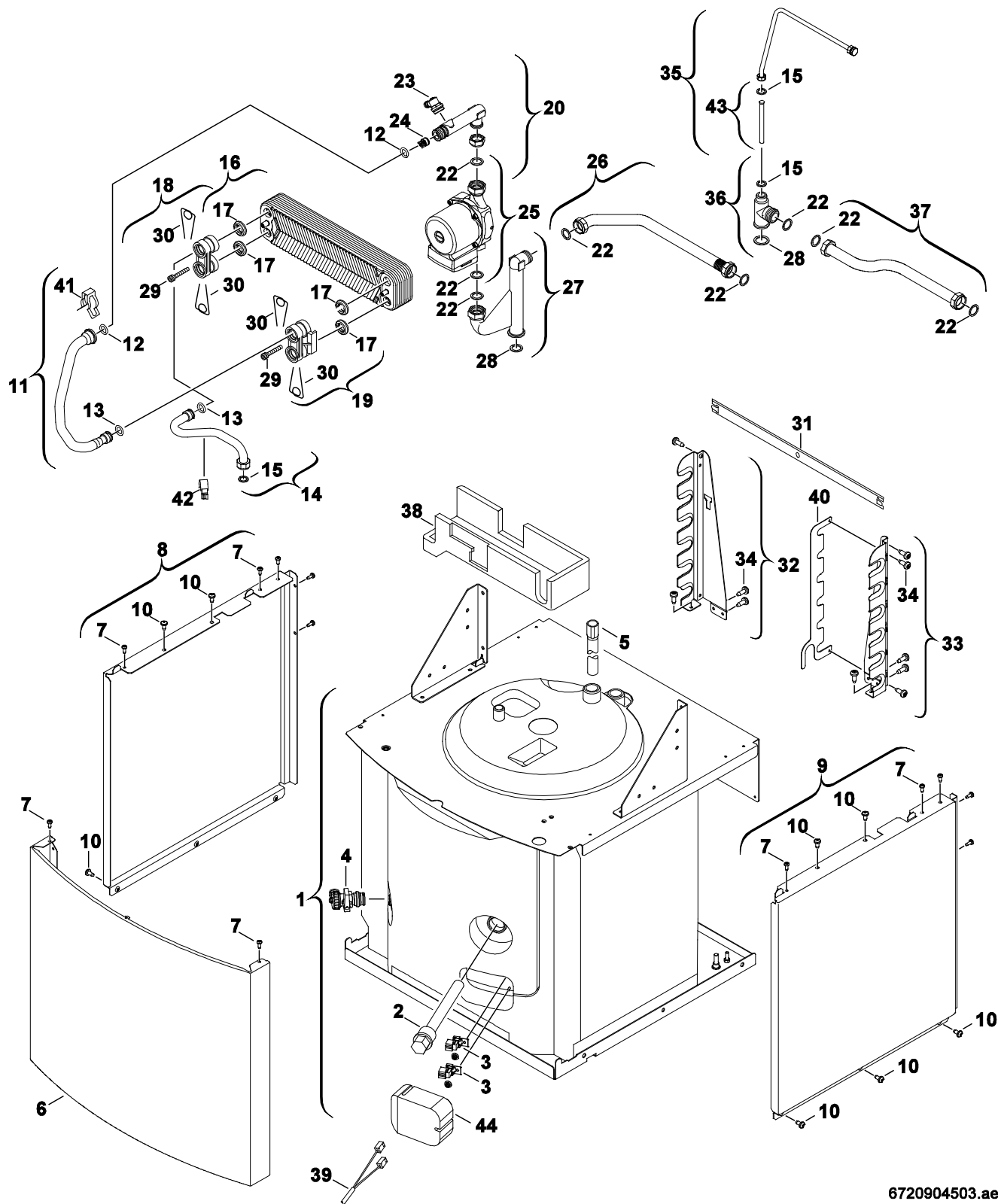

6720904503.ae.1

**7** Storage tank  
Speicherbehälter  
Ballon  
Bollitore  
**A** Voorraadvat

ZBS 16-30/83-170S-2MA/MRA/Solar

Pos	Description Bezeichnung Dénomination Descrizioni Benaming	S-Nr	Ordering no. Bestell-Nr. Numéro de commande N° d'ordine Bestelnummer	PG	TOP 30/260-2	TOP 30/375-2	TURBO TOWER 30 HRC	ZBS16/83S-2MA	ZBS16/83S-2MRA	ZBS16/120S-2MA	ZBS16/150S-2MA	ZBS22/83S-2MA	ZBS22/120S-2MA	ZBS22/120S-2MRA	ZBS22/150S-2MA	ZBS30/83S-2MA	ZBS30/150S-2MA			Remarks Bemerkungen Remarques Osservazioni Opmerkingen
1	Reservoir 83 L	0404,1400,3600,5000,5200,5300,7	8 715 407 299 0	63	■			■	■			■				■				
1	Reservoir 120 l	0700,0800,5000,5200,5300,6100,7	8 715 407 307 0	65			■			■			■	■						
1	Reservoir 150 L	0404,1400,3600,5000,5200,5300,6	8 715 407 312 0	66		■									■		■			
2	Anode 1" 200mm	0404,0700,0800,1400,3600,5000,5	8 718 505 037 0	34	■	■	■	■	■	■	■	■	■	■	■	■	■	■		
3	Temperature sensor		8 714 500 123 0	25	■	■	■	■	■	■	■	■	■	■	■	■	■	■		
4	KFE-Shut-off valve Acc.No.845	0404,0700,0800,1400,3600,5000,5	7 719 002 007		■	■	■	■	■	■	■	■	■	■	■	■	■	■		
5	Pipe		8 718 225 034 0	31	■	■	■	■	■	■	■	■	■	■	■	■	■	■		
6	Covering sheet	0404,1400,3600,5000,5200,5300,7	8 718 005 914 0	42	■			■	■			■				■				
6	Covering sheet	0700,0800,5000,5200,5300,6100,7	8 718 005 915 0	42			■			■			■	■						
6	Covering sheet	0404,1400,3600,5000,5200,5300,6	8 718 005 916 0	44		■									■		■			
7	Screw tapping no10 x 13 pan head		2 910 612 432 0	11	■	■	■	■	■	■	■	■	■	■	■	■	■	■		
8	Side panel left	0404,1400,3600,5000,5200,5300,7	8 715 407 319 0	40	■			■	■			■				■				
8	Side panel left	0700,0800,5000,5200,5300,6100,7	8 718 005 899 0	40			■			■			■	■						
8	Side panel left	0404,1400,3600,5000,5200,5300,6	8 718 005 901 0	42		■									■		■			
9	Side panel right	0404,1400,3600,5000,5200,5300,7	8 715 407 320 0	40	■			■	■			■				■				
9	Side panel right	0700,0800,5000,5200,5300,6100,7	8 718 005 900 0	40			■			■			■	■						
9	Side panel right	0404,1400,3600,5000,5200,5300,6	8 718 005 902 0	42		■									■		■			
10	Screw M6x13 phillips steel cross		2 910 619 454 0	16	■	■	■	■	■	■	■	■	■	■	■	■	■	■		
11	Pipe		8 710 735 339 0	35	■	■	■	■	■	■	■	■	■	■	■	■	■	■		
12	O-ring 17x4 (10x)		8 716 771 154 0	12	■	■	■	■	■	■	■	■	■	■	■	■	■	■		
13	O-ring 13,87x3,53 (10x)		8 716 771 155 0	22	■	■	■	■	■	■	■	■	■	■	■	■	■	■		
14	Pipe		8 710 735 338 0	32	■	■	■	■	■	■	■	■	■	■	■	■	■	■		
15	Washer 18.6 X 13.5 X 1.5 (10x)		8 710 103 045 0	11	■	■	■	■	■	■	■	■	■	■	■	■	■	■		
16	Heat exchanger		8 716 106 436 0	42	■	■	■	■	■	■	■	■	■	■	■	■	■	■		
17	Seal 15mm		8 716 106 435 0	15	■	■	■	■	■	■	■	■	■	■	■	■	■	■		
18	Connection bush		8 710 305 385 0	16	■	■	■	■	■	■	■	■	■	■	■	■	■	■		
19	Connection bush		8 710 305 387 0	16	■	■	■	■	■	■	■	■	■	■	■	■	■	■		
20	Connection union	0800,1400,5000,5200,5300,6100,7	8 711 304 902 0	38						■			■	■						
20	Connection union	5000,5200,5300,7200	8 711 304 903 0	38				■	■											
20	Connection union	0404,0700,1400,3600,5000,5200,5	8 713 305 762 0	40	■	■	■	■				■				■	■	■		
22	Sealing washer 23.9 X 17.2 X 1.5 (10x)		8 710 103 043 0	12	■	■	■	■	■	■	■	■	■	■	■	■	■	■		
23	Vent valve		8 717 405 285 0	21	■	■	■	■	■	■	■	■	■	■	■	■	■	■		
24	Swing check valve		8 718 505 023 0	17	■	■	■	■	■	■	■	■	■	■	■	■	■	■		
25	pump suitable for drinkwater		8 717 204 449 0	50	■	■	■	■	■	■	■	■	■	■	■	■	■	■		
26	Flow pipe	0404,0700,0800,1400,3600,5000,5	8 710 735 343 0	28	■	■	■	■	■	■	■	■	■	■	■	■	■	■		
27	Flow pipe	0404,0700,0800,1400,3600,5000,5	8 713 305 756 0	40	■	■	■	■	■	■	■	■	■	■	■	■	■	■		
28	Washer 1" (10x)		8 710 103 046 0	12	■	■	■	■	■	■	■	■	■	■	■	■	■	■		
29	Screw & washer assembly M5x30		8 716 106 452 0	14	■	■	■	■	■	■	■	■	■	■	■	■	■	■		
30	Clip Wire 18mm (10x)		8 718 684 699 0	22	■	■	■	■	■	■	■	■	■	■	■	■	■	■		
31	Fixing bracket		8 718 003 971 0	21	■	■	■	■	■	■	■	■	■	■	■	■	■	■		
32	Fixing bracket		8 711 304 823 0	23	■	■	■	■	■	■	■	■	■	■	■	■	■	■		
33	Fixing bracket		8 711 304 824 0	23	■	■	■	■	■	■	■	■	■	■	■	■	■	■		
34	Screw tapping no10 x 13 pan head		2 910 612 432 0	11	■	■	■	■	■	■	■	■	■	■	■	■	■	■		
35	Flow pipe		8 710 735 365 0	30	■	■	■	■	■	■	■	■	■	■	■	■	■	■		
36	Flow pipe		8 713 305 757 0	35	■	■	■	■	■	■	■	■	■	■	■	■	■	■		
37	Flow pipe		8 710 735 344 0	28	■	■	■	■	■	■	■	■	■	■	■	■	■	■		
38	Insulation		8 711 304 828 0	16	■	■	■	■	■	■	■	■	■	■	■	■	■	■		
39	Cable		8 714 402 124 0	29	■	■	■	■	■	■	■	■	■	■	■	■	■	■		
40	Connection plate		8 718 005 913 0	21	■	■	■	■	■	■	■	■	■	■	■	■	■	■		
41	Clip (10x) 18		8 711 200 024 0	22	■	■	■	■	■	■	■	■	■	■	■	■	■	■		
42	Temperature sensor		8 714 500 117 0	25	■	■	■	■	■	■	■	■	■	■	■	■	■	■		
43	Flow pipe		8 718 220 135 0	17	■	■	■	■	■	■	■	■	■	■	■	■	■	■		

**ZBS 16-30/83-170S-2MA/MRA/Solar**

Storage tank  
Speicherbehälter  
Ballon  
Bollitore  
Voorraadvat

**7A**

Spare parts list  
Ersatzteilliste

Liste des pièces de rechange  
Lista parti di ricambio

Onderdelenlijst

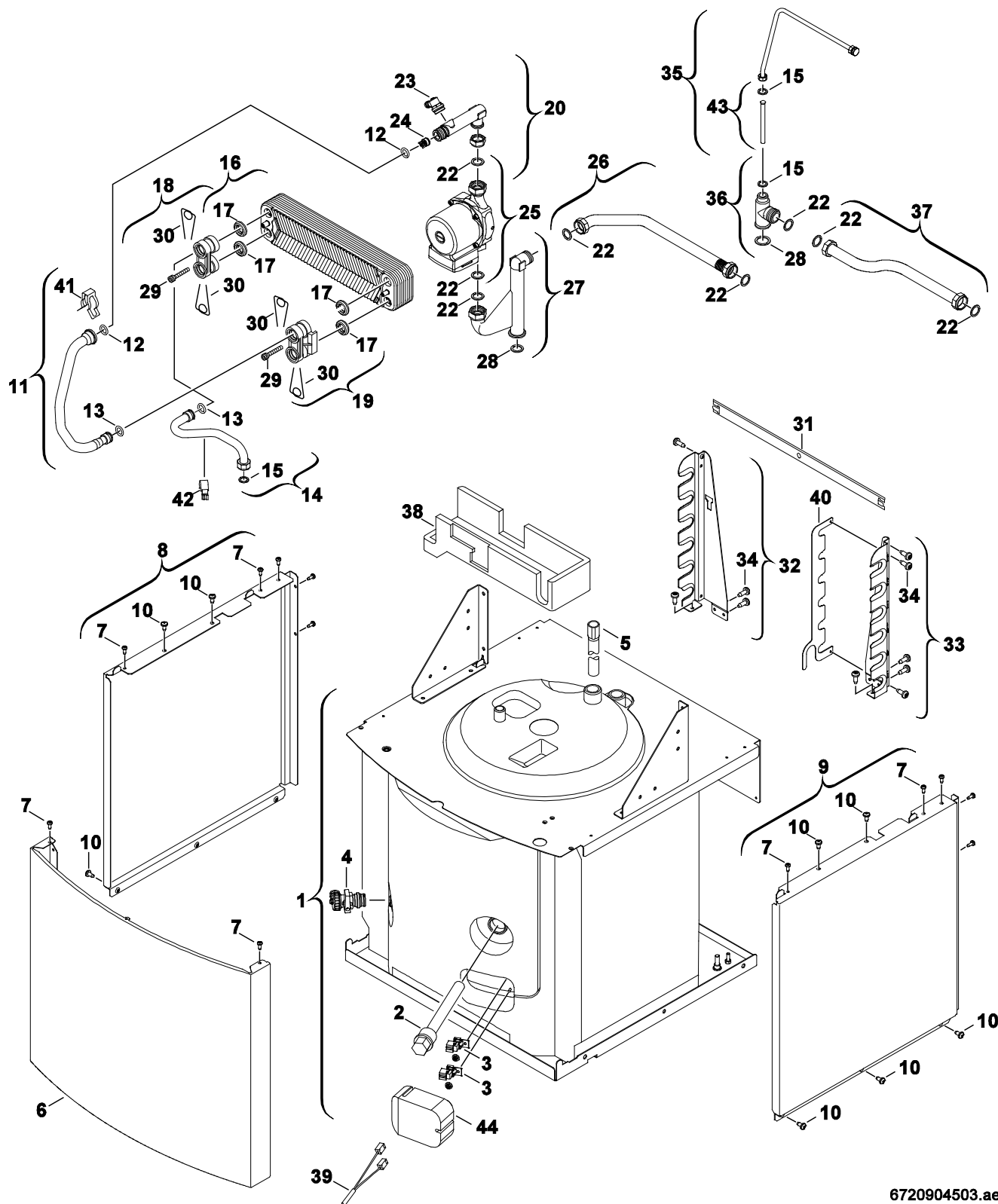

6720904503.ae.1

**7** Storage tank  
Speicherbehälter  
Ballon  
Bollitore  
**A** Voorraadvat

ZBS 16-30/83-170S-2MA/MRA/Solar



Spare parts list  
Ersatzteilliste

Liste des pièces de rechange  
Lista parti di ricambio

Onderdelenlijst

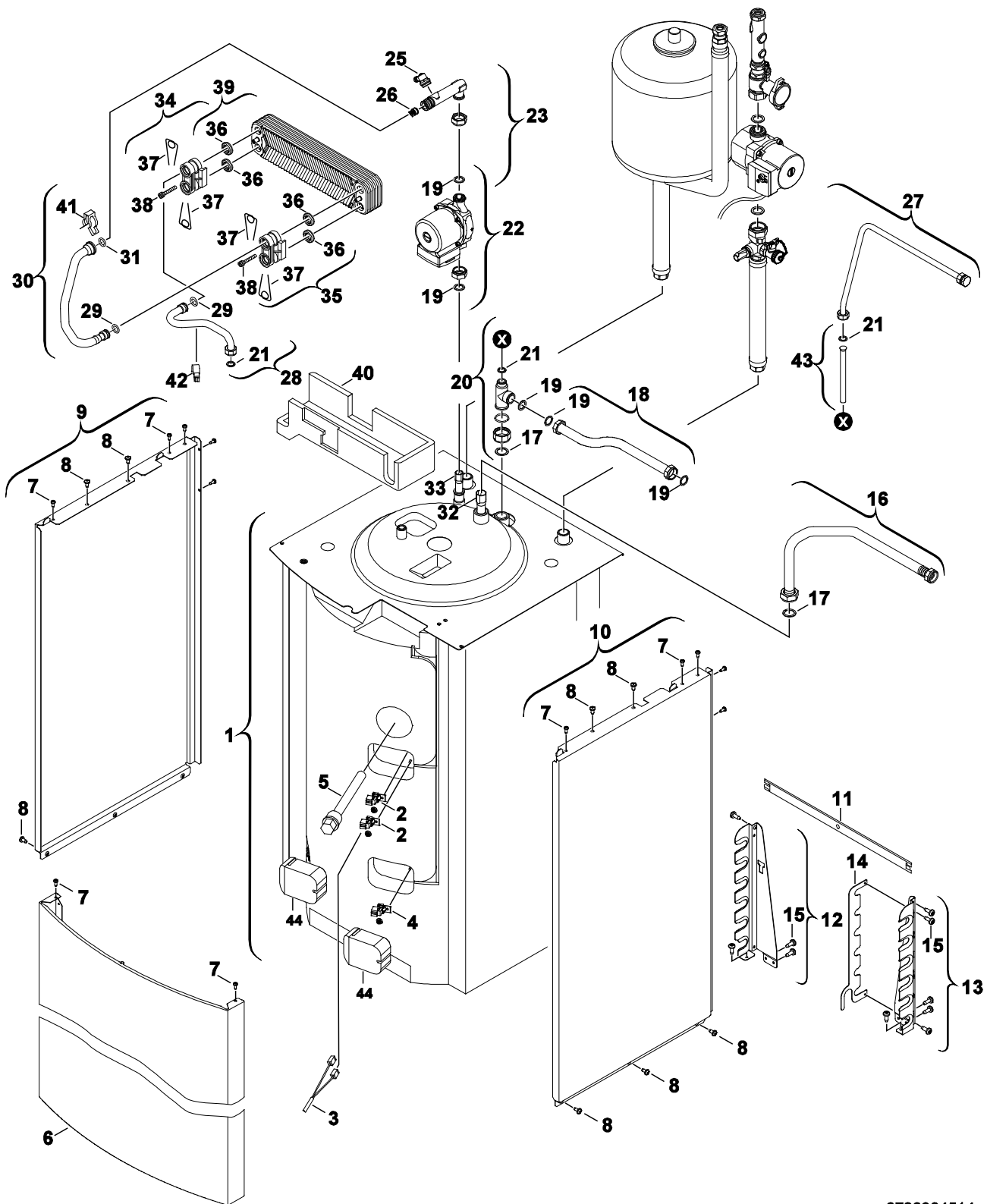

6720904514.ae.1

**7** Storage tank  
Speicherbehälter  
Ballon  
**B** Bollitore  
Voorraadvat

ZBS 16-30/83-170S-2MA/MRA/Solar



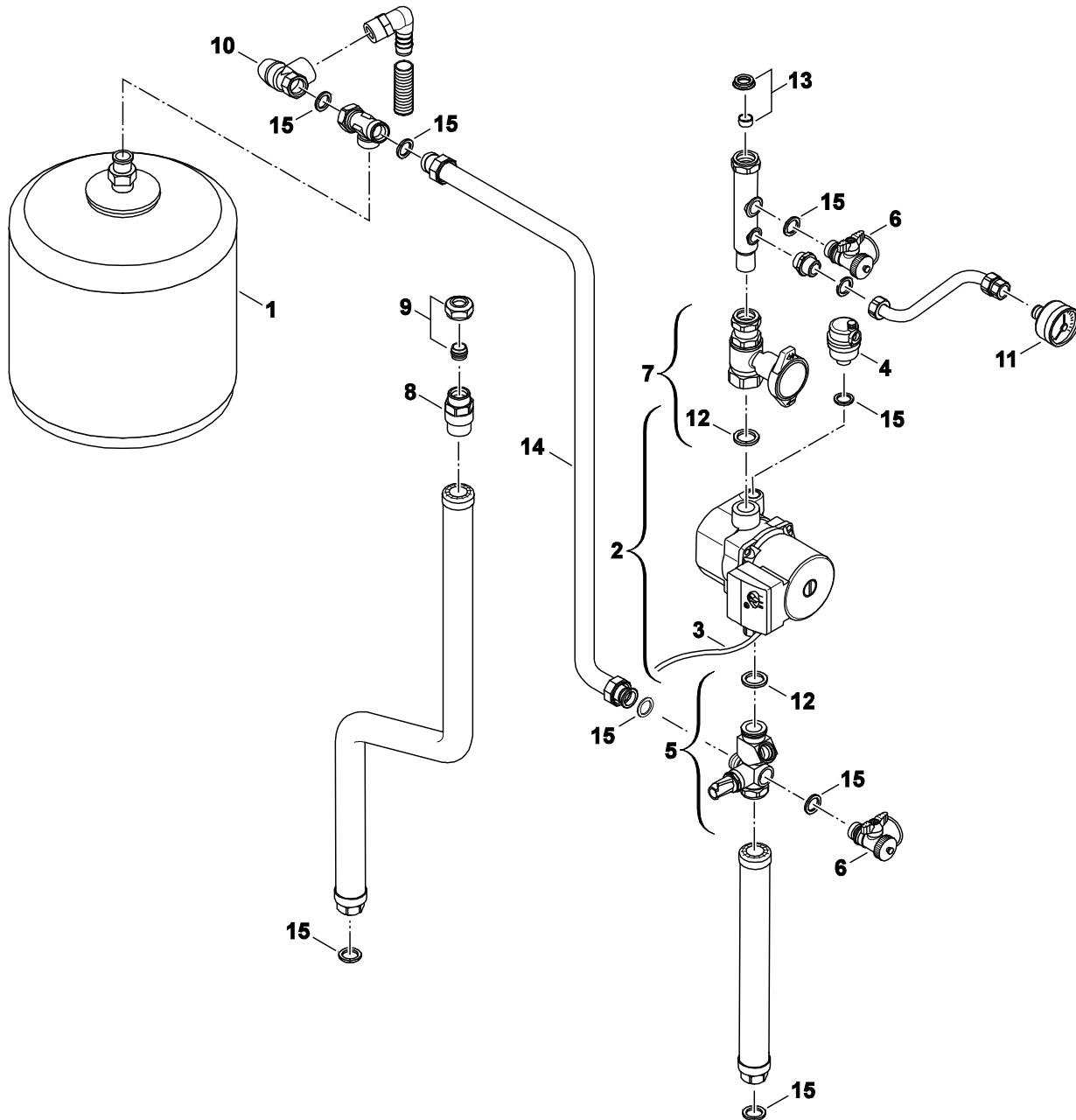

6720904872.AA/G

8

Solar hydraulics  
Solarhydraulik  
Hydraulique de solaire  
Idraulica solare  
Hydrauliek solar

ZBS 16-30/83-170S-2MA/MRA/Solar



Spare parts list  
Ersatzteilliste

Liste des pièces de rechange  
Lista parti di ricambio

Onderdelenlijst

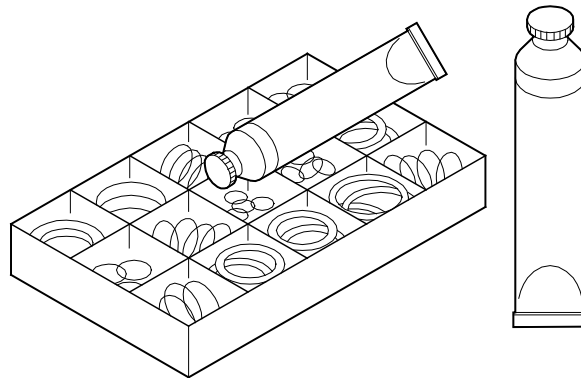

6720904217.AA/G

9

Service/Installation  
Wartung/Installation  
Service/Installation  
Servicio/Instalazione  
Service/Installatie

ZBS 16-30/83-170S-2MA/MRA/Solar

Pos	Description Bezeichnung Dénomination Descrizioni Benaming	S-Nr	Ordering no. Bestell-Nr. Numéro de commande N° d'ordine Bestelnummer	PG	TOP 30/260-2	TOP 30/375-2	TOP 30/400-2 SOLAR	TURBO TOWER 30 HRC	TURBO TOWER 30 HRC S	ZBS16/83S-2MA	ZBS16/83S-2MRA	ZBS16/120S-2MA	ZBS16/150S-2MA	ZBS16/170S-2solarMA	ZBS16/170S-solarMA	ZBS22/83S-2MA	ZBS22/120S-2MA	ZBS22/120S-2MRA	ZBS22/150S-2MA	ZBS22/150S-2MRA	ZBS30/83S-2MA	ZBS30/150S-2MA	ZBS30/170S-2solarMA	Remarks Bemerkungen Remarques Osservazioni Opmerkingen
	Brush set WB5 (Acc-N°. 1060)		7 719 002 502							■	■					■	■					■		
	Cleaning Tool WB5 (Acc-No1061)		7 719 002 503							■	■					■	■					■		
	Grease HFT1V5		8 709 918 010 0	19	■	■	■	■	■	■	■	■	■	■	■	■	■	■	■	■	■	■	■	■
	Set of washers		8 709 918 412 0	32	■	■	■	■	■	■	■	■	■	■	■	■	■	■	■	■	■	■	■	■
	Grease Unisilikon L641		8 709 918 413 0	19	■	■	■	■	■	■	■	■	■	■	■	■	■	■	■	■	■	■	■	■
	Sealing washer 23.9 X 17.2 X 1.5 (10x)		8 710 103 043 0	12	■	■	■	■	■	■	■	■	■	■	■	■	■	■	■	■	■	■	■	■
	Washer 18.6 X 13.5 X 1.5 (10x)		8 710 103 045 0	11	■	■	■	■	■	■	■	■	■	■	■	■	■	■	■	■	■	■	■	■
	Clip		8 711 301 084 0	18	■	■	■	■	■	■	■	■	■	■	■	■	■	■	■	■	■	■	■	■
	Barrel nipple 3/4" (1x)		8 713 305 666 0	16	■	■	■	■	■	■	■	■	■	■	■	■	■	■	■	■	■	■	■	■
	Barrel nipple	0404,0700,0800, 1400,5000,5200,5	8 713 305 667 0	21				■	■	■	■	■	■	■	■	■	■	■	■	■	■	■	■	■
	Heat conducting paste		8 719 918 658 0	30	■	■	■	■	■	■	■	■	■	■	■	■	■	■	■	■	■	■	■	■
	SET OF O-RINGS		8 719 928 253 0	38	■	■	■	■	■	■	■	■	■	■	■	■	■	■	■	■	■	■	■	■
	Outside temperature sensor		8 747 207 101 0	28							■							■						
<b>ZBS 16-30/83-170S-2MA/MRA/Solar</b>										Service/Installation Wartung/Installation Service/Installation Servicio/Instalazione Service/Installatie												<b>9</b>		

List of translations Übersetzungsliste		Liste des traductions Traduzione delle descrizioni	Vertalinglijst	
Pos	Beschreibung	Denomination	Descrizione	Benaming
<b>1</b>	<b>Baugruppe</b>	<b>Groupe de construction</b>	<b>Gruppo di costruzione</b>	<b>Montagegroep</b>
1	Abdeckung	Couvercle	Coperchio	Afdichting
2	Tür	Porte	Panello frontale	Deur
3	Dichtung	Joint	Guarnizione	Pakkingring
4	Seitenblende links	Habil gauche GB152T	Pannelli laterali sinistra	Zijpaneel links
5	Seitenblende rechts	Habil droit GB152T	Pannelli laterali destra	Zijpaneel rechts
6	Schraube BZ 4,8x13 (10x)	VIS DE FIXATION 4,8X13 (10X)	Vite BZ 4,8x13 (10x)	Schroef (10 x)
7	Haltefedersatz	Epingle	Molla	Borgveer
8	Ausdehnungsgefäß 18l	Vase d'expansion 18l	Vaso di espansione 18l	Expansievat 18l
9	Schnellentlüfter	Purgeur	Valvola sfiato aria	Vlotterontluchter
10	Abdeckung	Couvercle	Coperchio	Afdichting
11	Abgasstutzen	Raccordement ventouse	Terminale condotto	Rookgasafvoerstuts
12	Stopfen	Bouchon	Coperchietto -	Doorvoertule
13	Dichtung d: 80mm	Joint #80mm	Guarnizione #80mm	Pakkingring #80 mm
14	Schelle	Collier d.125	Staffa	Klembeugel
15	Abgasrohr	Tuyau d'évacuation gaz	Condotto fumi	Afvoerpijp
16	Dichtung d: 80mm	Joint #80mm	Guarnizione #80mm	Pakkingring #80 mm
17	Dichtring	Joint	Guarnizione	Pakkingring
18	Dichtring # 87,5mm	Joint # 87,5mm	Guarnizione # 87,5mm	Pakkingring # 87,5mm
19	Verschlusssatz	Sachet de serrure	Coperchio	Afsluitingsset
20	Schraube (10x)	VIS (10X)	Vite (10x)	Schroef (10 x)
21	Logo Junkers	Marquage Junkers	Targhetta Junkers	LOGO JUNKERS ZELFKLEVEND
21	Logo Bosch	Marquage Bosch	Logo Bosch	LOGO BOSCH ZELFKLEVEND
<b>2</b>	<b>Baugruppe</b>	<b>Groupe de construction</b>	<b>Gruppo di costruzione</b>	<b>Montagegroep</b>
1	Wärmetauscher basic block	Echangeur de chaleur	Scambiatore di calore	Warmtewisselaar
2	Mutter	Ecrou	Sostegno	Stuts
3	Temperaturbegrenzer	Limiteur de température	Limitatore temperatura	Temperatuurbegrenzer
4	Deckel	Couvercle	Coperchio	Deksel
5	Dichtung	Joint	Guarnizione	Afdichting deksel
6	Abschirmblech	Tôle de protection	Lamierino	Afschermplaat
7	Elektrodensatz	Jeu d'électrodes	Set di elettrodi -	Elektrodenset
8	Temperaturfühler	Sonde de température	Sensore termometrico	Temperatuurvoeler
9	Brenner	Br#leur	Brucciato	Brander
10	Brennerdichtung	Joint de br#leur	Guarnizione bruciatore	Brander afdichting
11	Befestigungssatz	Joint de fixation	Set di fissaggio	Bevestigingsset
12	Deckel	Couvercle	Coperchio	Deksel
13	Befestigungssatz	Joint de fixation	Set di fissaggio	Bevestigingsset
14	Befestigungssatz	Joint de fixation	Set di fissaggio	Bevestigingsset
15	Scheibe (10x)	Rondelle (10x)	Rondella (10x)	Onderlegging (10x)
16	Dichtung (10x)	Joint (10x)	Guarnizione (10x)	Afdichting (10x)
17	Abgassammler	Coupe tirage antirefouleur	Cappa fumi	Condensbak
22	Temperaturbegrenzer kpl	Limiteur de température	Limitatore temperatura	Temperatuurbegrenzer incl. pakking
	Service Kit WB5	Service Kit WB5	Service Kit WB5	Service Kit WB5
<b>4</b>	<b>Baugruppe</b>	<b>Groupe de construction</b>	<b>Gruppo di costruzione</b>	<b>Montagegroep</b>
1	Gebälse	Ventilateur	Ventilatore	Ventilador
2	Dichtring	Joint	Guarnizione	Pakking
3	Luftbegrenzer	Chambre de melange	Modulo di miscelazio	Meng inrichting
4	Luftbegrenzer	Chambre de melange	Modulo di miscelazio	Meng inrichting
5	Gasrohr	Tube gaz	Tubo gas	Gaspipj
6	Plombe (10x)	Plomb (x10)	Piombino (10x)	Loodje (10x)
7	O-Ring 12x3 (10x)	Joint torique 12x3 (10x)	Anello tenuta 12x3 (10x)	O-ring 12 x 3 (10 x)
8	Überwurfmutter	Ecrou	Dado	Wartelmoer
9	Kappe (10x)	Capot de protection (10x)	Sigillo (10x)	Beschermkap (10x)
10	Dichtung	Joint	Guarnizione	Pakkingring
11	Gasarmatur CE427	Bloc gaz CE427	Gruppo gas CE427	Gasregelblok CE427
12	Kappe (10x)	Capot de protection (10x)	Sigillo (10x)	Beschermkap (10x)
13	Plombe (10x)	Plomb	Piombino (10x)	Loodje (10x)

List of translations Übersetzungsliste		Liste des traductions Traduzione delle descrizioni		Vertalinglijst
Pos	Beschreibung	Denomination	Descrizione	Benaming
14	Gaszuführungsrohr	Tube arrivée gaz	Tubo gas	Gastoevoerpijp
15	Drosselbuchse (38)	Coussinet limiteur (38)	Boccola di strozzaggio(38)	Regelventiel geel (38)
15	Drosselbuchse (27)	Coussinet limiteur (27)	Buccola di strozzaggio (27)	Regelventiel geel (27)
16	O-Ring (10x)	Joint torique (10x)	Anello tenuta (10x)	O-ring (10x)
17	Dichtscheibe 3/4" (10x)	Joint 3/4" (x10)	Guarnizione 3/4" (10x)	Afdichtring 3/4" (10x)
18	Dichtscheibe 1/2" (10x)	Joint 1/2" (x10)	Guarnizione 1/2" (10x)	Afdichtring 1/2" (10x)
19	Membranteller	Membrane	Piatello	Overdrachtplaat met stift
	Gasart-Umbausatz 21,23>31	Kit de transformation de gaz 21,23>31	Kit conversione gas 21,23>31	Gasombouwset 21,23>31
	Gasart-Umbausatz 31>21,23	Kit de transformation de gaz 31>21,23	Kit conversione gas 31>21,23	Gasombouwset 31>21,23
	Gasartumbausatz 21,23 ->31	Kit de transf.de gaz 21,23>31	Kit conversione gas 21,23>31	Gasombouwset 21,23>31
	Gasartumbausatz 31-> 21,23	Kit de transf.de gaz 31>21,23	Kit conversione gas 31>21,23	Gasombouwset 31>21,23
	Gasart-Umbausatz 23>31	Kit de transformation de gaz	Kit conversione gas	Gasombouwset
<b>5</b>	<b>Baugruppe</b>	<b>Groupe de construction</b>	<b>Gruppo di costruzione</b>	<b>Montagegroep</b>
1	Rohr	Tube	Tubo	Pijp
2	Dichtscheibe 1" (10x)	Joint 1" (10x)	Guarnizione 1" (10x)	Afdichting 1" (10x)
3	Dichtscheibe 3/4" (10x)	Joint 3/4" (x10)	Guarnizione 3/4" (10x)	Afdichtring 3/4" (10x)
4	O-Ring 13,87x3,53 (10x)	Joint torique 13,87x3,53 (x10)	Anello tenuta 13,87x3,53 (10x)	O-ring 13,87x3,53 (10x)
6	Entlüftungsleitung	Tube de dégazage	Separatore	Ontluchtingspijp
7	Dichtscheibe 1/2" (10x)	Joint 1/2" (x10)	Guarnizione 1/2" (10x)	Afdichtring 1/2" (10x)
8	Rohr	Tube	Tubo	Pijp
10	Anschlussrohr	Tuyauterie	Tubo di raccordo	Aansluitpijp
11	Rohr	Tube	Tubo	Pijp
12	O-Ring 13,87x3,53 (10x)	Joint torique 13,87x3,53 (x10)	Anello tenuta 13,87x3,53 (10x)	O-ring 13,87x3,53 (10x)
13	Anschlussrohr	Tuyauterie	Tubo di raccordo	Aansluitpijp
14	Rücklaufrohr	Tube de raccordement retour chauffage	Tubazione di ritorno	Retourleiding
15	O-Ring (10x)	O-ring (10x)	Anello tenuta (10x)	O-ring (10x)
16	Haltefeder (10x)	Epingle (10x)	Molla (10x)	Borgveer (10x)
17	Haltefeder (10x)	Epingle (10x)	Molla (10x)	Borgveer (10x)
18	Pumpe DDPWM 15-60 130mm G1 230V 50Hz	Circul. DDPWM 15-60 130mm G1 230V 50Hz	Pompa DDPWM 15-60 130mm G1 230V 50Hz	Pomp DDPWM 15-60 130mm G1 230V 50Hz
18	Pumpe UPS 15-35-50 130mm G1 230V 50Hz	Circul. UPS 15-35-50 130mm G1 230V 50Hz	Pompa UPS 15-35-50 130mm G1 230V 50Hz	Pomp UPS 15-35-50 130mm G1 230V 50Hz
19	Pumpenkabel	Faisceau circulateur	Cablaggio de pompa	Pompkabel
20	Manometer	Manom#tre	Manometro	Manometer
21	O-Ring (10x)	O-ring (10x)	Anello tenuta (10x)	O-ring (10x)
22	Haltefeder (10x)	Epingle (10x)	Molla (10x)	Borgveer (10x)
23	3-Wegeventil	Vanne 3 voies	3-vie valvola	3-wegklep
24	Sicherheitsventil 3bar	Soupape de sécurité 3bar	Valvola sicurezza 3bar	Veiligheidsklep 3bar
25	Adapter	Raccord	Adattore	Adapter
26	Dichtscheibe (10x)	Joint (10x)	Guarnizione (10x)	Afdichting (10x)
27	O-Ring 13,87x3,53 (10x)	Joint torique 13,87x3,53 (x10)	Anello tenuta 13,87x3,53 (10x)	O-ring 13,87x3,53 (10x)
28	Haltefeder (10x)	Epingle (10x)	Molla (10x)	Borgveer (10x)
29	Motor	Servomoteur	Motore	Motor
30	Schlauch	Flexible	Tubo flessibile	Slang
32	Kappe	Capot de protection	Sigillo	Beschermkap
33	Deckel	Couvercle	Coperchio nero	Deksel
34	Wellrohr	Tuyau flexible	Tubo ondulato	Flexibele leiding
35	O-Ring-Set	Joint torique	Set di anello tenuta	O-ring
36	Haltefeder 18 mm (10x)	Epingle 18 mm (10x)	Fermo a molla 18 mm (10x)	Borgveer 18 mm (10x)
37	Schnellentlüfter	Purgeur	Valvola sfiato aria	Vlotterontluchter
38	Adapter 3/8"	Raccord 3/8"	Adattore 3/8"	Adapter 3/8"
39	Syphon	Siphon	Sifone	Sifon
40	Deckel	Tube de révision DN80 KF	Coperchio nero	Dop sifon
41	Dichtungssatz (10x)	Sachet de joints (10x)	Set di guarnizioni (10x)	Set afdichting # 61 (10x)
42	O-Ring 26,34 x 5,33 (5x)	Joint torique 26,34 x 5,33 (x5)	Anello tenuta 26,34 x 5,33 (5x)	O-ring 26,34 x 5,33 (5x)
43	Schlauch	Tuyau d évacuation	Tubo flessibile	Slang
44	Kondensatablauf	Evacuation des condensats	Condense uscita	Condensafvoer
<b>6</b>	<b>Baugruppe</b>	<b>Groupe de construction</b>	<b>Gruppo di costruzione</b>	<b>Montagegroep</b>
1	Steuergerät	Tableau électrique	Cassetta ionizzazione	HEATRONIC II CERASMARTMODUL

List of translations Übersetzungsliste		Liste des traductions Traduzione delle descrizioni	Vertalinglijst	
Pos	Beschreibung	Denomination	Descrizione	Benaming
2	Leiterplatte	Circuit imprimé	Scheda elettronica	Print
3	Abstandhalter (10x)	Entretoise (10x)	Distanziale (10x)	Afstandhouder (10x)
4	Steckersatz	Plots connexion	Morsetto	Stekker set
5	Sicherung T2,5A (10x)	Fusible T2,5A (x10)	Fusibile T2,5A (10x)	Zekering T2,5A (10x)
6	Sicherung T0,5A (10x)	Fusible T0,5A (x10)	Fusibile T0,5A (10x)	Zekering T0,5A (10x)
7	Sicherung T1,6A (10x)	Fusible T1,6A (x10)	Fusibile T1,6A (10x)	Zekering T1,6A (10x)
8	Transformator	Transformateur	Trasformatore primario	Transformator
9	Schraube (10x)	Vis (10x)	Vite (10x)	Schroef (10 x)
10	Kabelbaum	Faisceau	Cablaggio	Kabel set
11	Zündkabel	Faisceau d'electrodes	Cavetto accensione	Hoogspanningsleiding
12	Pumpenkabel	Faisceau circulateur	Cablaggio de pompa	Pompkabel
13	Gehäuse hellgrau	Carter gris clair	Involucro grigio chiaro	Beschermt lichtgrijs
14	Drehgriffe hellgrau	Croisillons gris clairs	Manopola grigio chiaro	Schakelknop lichtgrijs
17	TA211E/C1	TA211E/C1	TA211E/C1	TA211E/C1
18	DT2 telegrau	GREENSTAR DIGITAL TIMER	DT 2(GRIGIO CHIARO)	DT 2/C1 INBOUWKLOK "CERASMART"
19	Blende hellgrau	Sachet caches gris clair	Mascherina grigio chiaro	Paneel lichtgrijs
20	Kodierstecker 1012	Cl de codage 1012	Spina codifica 1012	Codeer stekker 1012
20	Kodierstecker (50)	Circuit imprimé de codage	Spina codifica	KODEERSTEKKER "23" TOP 28 ZSB-TOP 30 ZWB
20	Kodierstecker	Cl de codage	Spina codifica	Codeer stekker
21	Sichtfenster	Hublot	Vetrinoo	Kijkglas
22	Blende	Cache	Mascherina	Paneel
23	Blende	Cache	Mascherina	Paneel
24	Regler	Régulateur	Regolator	Regelaar
25	Abdeckung	Couvercle	Coperchio	Afdichting
26	Speicherfühler PT1000	Sonde de temperature	Sensore termometrico TF1	Temperatuurvoeler
27	Kabel	Faisceau	Cablaggio	Kabel
	Sicherungssatz T0,5/T1,6/T2,5/T3,15A	Sachet fusibles T0,5/T1,6/T2,5/T3,15A	Set di fusibili T0,5/T1,6/T2,5/T3,15A	Zekeringset T0,5/T1,6/T2,5/T3,15A
<b>7A</b>	<b>Baugruppe</b>	<b>Groupe de construction</b>	<b>Gruppo di costruzione</b>	<b>Montagegroep</b>
1	Behälter 83 L	Ballon de stockage 83 L	Sostegno 83 L	VOORRAADVAT 83 L TOP 30/260-2ZBS
1	Behälter 120 l	Ballon de stockage 120 l	Sostegno 120 l	Reservoir 120 l
1	Behälter 150 L	Ballon de stockage 150 L	Sostegno 150 L	VOORRAADVAT 150 L TOP 30/375-2ZBS
2	Anode isoliert 1" 200mm	Anode 1" 200mm	Anodo 1" 200mm	Anode 1" 200mm
3	Temperaturfühler	Sonde de temperature	Sensore termometrico	Temperatuurvoeler
4	Nr.845 KFE-Hahn Zubehör	Robinete de vidange/remplissage ECS	KFE-Rubineto di intercettazione No.845	KFE-Serviceafsluiter Zub.Nr.845
5	Rohr Tauchrohr Lg.940	Tube d'arrivée/évacuation	Tubo della presa/ entrata	DOMPELBUIS WW TOP30-260/375/400-2ZSB
6	Abdeckung	Couvercle	Coperchio	Afdichting
7	Schraube BZ 4,8x13 (10x)	VIS DE FIXATION 4,8X13 (10X)	Vite BZ 4,8x13 (10x)	Schroef (10 x)
8	Seitenwand links	Côté gauche	Pannelo laterale sinistra	ZIJPANEEL LINKS VAT 83 L
9	Seitenwand rechts	Côté droit	Pannelo laterale a destra	ZIJPANEEL RECHTS VAT 83 L
10	Schraube (10x)	VIS (10X)	Vite (10x)	Schroef (10 x)
11	Rohr	Tube	Tubo	Pijp
12	O-Ring 17x4 (10x)	Joint torique 17x4 (x10)	Anello tenuta 17x4 (10x)	O-ring 17 x 4 (10 x)
13	O-Ring 13,87x3,53 (10x)	Joint torique 13,87x3,53 (x10)	Anello tenuta 13,87x3,53 (10x)	O-ring 13,87x3,53 (10x)
14	Rohr	Tube	Tubo	Pijp
15	Dichtscheibe 1/2" (10x)	Joint 1/2" (x10)	Guarnizione 1/2" (10x)	Afdichtring 1/2" (10x)
16	Wärmeübertrager	Echangeur	Blocco lamellare	Ketelblok
17	Dichtung Sek WÜ 15mm	Joint d'etancheite Sek WÜ 15mm	Gomma di tenuta Sek WÜ 15mm	Afdichtingsrubber Sek WÜ 15mm
18	Anschlussbuchse	DOUILLE FILETEE	Piattello di collegamento	Aansluitstuk (bus)
19	Anschlussbuchse	DOUILLE FILETEE	Piattello di collegamento	Aansluitstuk (bus)
20	Verschraubung	Raccord sonde sanitaire	Raccordo	Koppeling
22	Dichtscheibe 3/4" (10x)	Joint 3/4" (x10)	Guarnizione 3/4" (10x)	Afdichtring 3/4" (10x)
23	Entlüftungsventil	Degazeur GB152T	Valvola di scarico	Beluchterventiel
24	Rückflußverhinderer	Clapet anti-retour GB152T	Ritorno di blocco	Terugslagventiel
25	Pumpe nur für Trinkwasser geeignet	Pompe pour l'eau potable uniquement	Pompa adatta solo per acqua potabile	Pomp alleen geschikt voor drinkwater
26	Rohr Anschlussrohr	Tube	Tubo di raccordo	Aansluitpijp
27	Anschlussrohr	Tuyau raccord GB152T83S	Tubo di raccordo	Aansluitpijp
28	Dichtscheibe 1" (10x)	Joint 1" (10x)	Guarnizione 1" (10x)	Afdichting 1" (10x)

	List of translations Übersetzungsliste	Liste des traductions Traduzione delle descrizioni		Vertalinglijst
Pos	Beschreibung	Denomination	Descrizione	Benaming
29	Schraube M5x30 mit Scheibe	Vis et joint M5x30	Set di fissaggio M5x30	Bevestigingsset M5x30
30	Haltefeder 18 mm (10x)	Epingle 18 mm (10x)	Fermo a molla 18 mm (10x)	Borgveer 18 mm (10x)
31	Halter	Support	Angolare	Steunbeugel
32	Haltewinkel	Tôle de fixation	Angolare	Steunhoek
33	Haltewinkel	EQUERRE FIXATION ARR DROIT GB152T	Angolare	Steunhoek
34	Schraube BZ 4,8x13 (10x)	VIS DE FIXATION 4,8X13 (10X)	Vite BZ 4,8x13 (10x)	Schroef (10 x)
35	Anschlussrohr	Tuyauterie	Tubo di raccordo	Aansluitpijp
36	Anschlussrohr	Tuyauterie tube plongeur GB152t150	Tubo di raccordo	Pijp
37	Anschlussrohr	Tuyauterie	Tubo di raccordo	Aansluitpijp
38	Isolierung	Isolation	Isolamento	Isolatie
39	Kabel	Faisceau	Cablaggio	Kabel
40	Halteblech	Plaque de jonction	Lamierino	Vangschaal
41	Klammer (10x) 18	Clip (x10)	Graffa (10x) 18	Klem (10 x)
42	Temperaturfühler	Sonde de temperature	Sensore termometrico	Temperatuurvoeler
43	Anschlussrohr	Tuyauterie	Tubo di raccordo	Aansluitpijp
44	Isolierung	Isolation	Isolamento	Isolatie
<b>7B</b>	<b>Baugruppe</b>	<b>Groupe de construction</b>	<b>Gruppo di costruzione</b>	<b>Montagegroep</b>
1	Behälter 170 l	Ballon de stockage 170 l	Bollitore 170 L.	Reservoir 170 l
2	Temperaturfühler	Sonde de temperature	Sensore termometrico	Temperatuurvoeler
3	Kabel	Faisceau	Cablaggio	Kabel
4	Temperaturfühler	Sonde de temperature	Sensore termometrico	Temperatuurvoeler
5	Anode isoliert, 1" 480mm	Anode 1" 480MM	Anodo 1" 480MM	Anode 1" 480MM
6	Abdeckung	Facade avant ballon 170sr	Coperchio	Afdichting
7	Schraube BZ 4,8x13 (10x)	VIS DE FIXATION 4,8X13 (10X)	Vite BZ 4,8x13 (10x)	Schroef (10 x)
8	Schraube (10x)	VIS (10X)	Vite (10x)	Schroef (10 x)
9	Seitenwand links	Côté gauche	Pannelo laterale sinistra	Zijpaneel links
10	Seitenwand rechts	Côté droit	Pannelo laterale a destra	Zijpaneel rechts
11	Halter	Support	Angolare	Steunbeugel
12	Haltewinkel	Tôle de fixation	Angolare	Steunhoek
13	Haltewinkel	EQUERRE FIXATION ARR DROIT GB152T	Angolare	Steunhoek
14	Halteblech	Plaque de jonction	Lamierino	Vangschaal
15	Schraube BZ 4,8x13 (10x)	VIS DE FIXATION 4,8X13 (10X)	Vite BZ 4,8x13 (10x)	Schroef (10 x)
16	Anschlussrohr	Tuyauterie	Tubo di raccordo	Aansluitpijp
17	Dichtscheibe 1" (10x)	Joint 1" (10x)	Guarnizione 1" (10x)	Afdichting 1" (10x)
18	Anschlussrohr	Tuyauterie	Tubo di raccordo	Aansluitpijp
19	Dichtscheibe 3/4" (10x)	Joint 3/4" (x10)	Guarnizione 3/4" (10x)	Afdichtring 3/4" (10x)
20	Anschlussrohr	Tuyauterie tube plongeur GB152t150	Tubo di raccordo	Pijp
21	Dichtscheibe 1/2" (10x)	Joint 1/2" (x10)	Guarnizione 1/2" (10x)	Afdichtring 1/2" (10x)
22	Pumpe nur für Trinkwasser geeignet	Pompe pour l'eau potable uniquement	Pompa adatta solo per acqua potabile	Pomp alleen geschikt voor drinkwater
23	Verschraubung	Raccord sonde sanitaire	Raccordo	Koppeling
25	Entlüftungsventil	Degazeur GB152T	Valvola di scarico	Beluchterventiel
26	Rückflußverhinderer	Clapet anti-retour GB152T	Ritorno di blocco	Terugslagventiel
27	Anschlussrohr	Tuyauterie	Tubo di raccordo	Aansluitpijp
28	Rohr	Tube	Tubo	Pijp
29	O-Ring 13,87x3,53 (10x)	Joint torique 13,87x3,53 (x10)	Anello tenuta 13,87x3,53 (10x)	O-ring 13,87x3,53 (10x)
30	Rohr	Tube	Tubo	Pijp
31	O-Ring 17x4 (10x)	Joint torique 17x4 (x10)	Anello tenuta 17x4 (10x)	O-ring 17 x 4 (10 x)
32	Rohr Tauchrohr Lg.940	Tube d'arrivée/évacuation	Tubo della presa/ entrata	DOMPELBUIS WW TOP30-260/375/400-2ZSB
33	Rohr-Tauchrohr, 915mm	Tube d'immersion 915mm	Tubo ad immersione 915mm	Dompelbuis 915mm
34	Anschlussbuchse	DOUILLE FILETEE	Piattello di collegamento	Aansluitstuk (bus)
35	Anschlussbuchse	DOUILLE FILETEE	Piattello di collegamento	Aansluitstuk (bus)
36	Dichtung Sek WÜ 15mm	Joint d'etancheite Sek WÜ 15mm	Gomma di tenuta Sek WÜ 15mm	Afdichtingsrubber Sek WÜ 15mm
37	Haltefeder 18 mm (10x)	Epingle 18 mm (10x)	Fermo a molla 18 mm (10x)	Borgveer 18 mm (10x)
38	Schraube M5x30 mit Scheibe	Vis et joint M5x30	Set di fissaggio M5x30	Bevestigingsset M5x30
39	Wärmeübertrager	Echangeur	Blocco lamellare	Ketelblok
40	Isolierung	Isolation	Isolamento	Isolatie
41	Klammer (10x) 18	Clip (x10)	Graffa (10x) 18	Klem (10 x)



Types of appliances Gerätetypen		Types de chaudières Tipo apparecchi		Toesteltypes	
Appliance Gerät Chaudière Apparecchio Toestel	Ordering no. Bestell-Nr. Numéro de commande N° d'ordine Bestellnummer	Country Land Pays Paese Land	S-Nr. S-Nr. S-Nr. S-Nr.	Remarks Bemerkungen Remarques Osservazioni Opmerkingen	
<b>ZBS16/150S-2MA23S1400</b>	7 714 410 021	Austria	1400		
<b>ZBS22/83S-2MA23S1400</b>	7 714 410 020	Austria	1400		
<b>ZBS22/150S-2MA23S1400</b>	7 714 410 022	Austria	1400		
<b>ZBS16/83S-2MA23</b>	7 714 311 001	Austria,Germany			
<b>ZBS16/170S-2SOLARMA23</b>	7 714 311 004	Austria,Germany			
<b>ZBS22/120S-2MA23</b>	7 714 311 005	Austria,Germany			
<b>ZBS22/120S-2MRA23</b>	7 714 311 002	Austria,Germany			
<b>ZBS22/120S-2MRA31</b>	7 714 321 002	Austria,Germany			
<b>ZBS30/150S-2MA23</b>	7 714 311 003	Austria,Germany			
<b>ZBS16/83S-2MA23 S5000</b>	7 714 311 006	Austria,Hungary	5000		
<b>ZBS22/120S-2MA23 S5000</b>	7 714 311 007	Austria,Hungary	5000		
<b>ZBS16/83S-2MA23S7200</b>	7 714 311 051	Austria,Slovenia	7200		
<b>ZBS22/120S-2MA23 S7200</b>	7 714 311 018	Austria,Slovenia	7200		
<b>TOP 30/260-2 ZBS</b>	7 714 311 026	Belgium	3600		
<b>TOP 30/375-2 ZBS</b>	7 714 311 028	Belgium	3600		
<b>TOP 30/400-2 ZBS SOLAR</b>	7 714 311 029	Belgium	3600		
<b>ZBS30/150S-2MA23 S7400</b>	7 714 311 019	Croatia,Slovenia	7400		
<b>ZBS16/83S-2MA23S5200</b>	7 714 311 009	Czech Republic	5200		
<b>ZBS22/120S-2MA23S5200</b>	7 714 311 010	Czech Republic	5200		
<b>ZBS30/150S-2MA23S5200</b>	7 714 311 011	Czech Republic	5200		
<b>ZBS16/120S-2MA23S0800</b>	7 714 311 030	Denmark	0800		
<b>ZBS16/170S-2SOLARMA23S0800</b>	7 714 410 031	Denmark	0800		
<b>ZBS22/120S-2MA23S0800</b>	7 714 311 031	Denmark	0800		
<b>ZBS30/170S-2SOLARMA23S6100</b>	7 714 410 033	Estonia,Latvia,Lithuania	6100		
<b>ZBS16/83S-2MA21</b>	7 714 301 001	Germany			

Types of appliances Gerätetypen	Types de chaudières Tipo apparecchi		Toesteltypes	
Appliance Gerät Chaudière Apparecchio Toestel	Ordering no. Bestell-Nr. Numéro de commande N° d'ordine Bestelnummer	Country Land Pays Paese Land	S-Nr. S-Nr. S-Nr. S-Nr. S-Nr.	Remarks Bemerkungen Remarques Osservazioni Opmerkingen
<b>ZBS16/83S-2MRA21</b>	7 714 301 000	Germany		
<b>ZBS16/83S-2MRA31</b>	7 714 321 000	Germany		
<b>ZBS16/170S-2SOLARMA21</b>	7 714 301 004	Germany		
<b>ZBS22/120S-2MA21</b>	7 714 301 005	Germany		
<b>ZBS22/120S-2MRA21</b>	7 714 301 002	Germany		
<b>ZBS30/150S-2MA21</b>	7 714 301 003	Germany		
<b>ZBS16/83S-2MRA23</b>	7 714 311 000	Germany,Slovenia		
<b>ZBS30/150S-2MA23 S5000</b>	7 714 311 008	Hungary	5000	
<b>ZBS16/83S-2MA</b>	7 714 410 028	Italy	0404	
<b>ZBS16/170S-2 SOLAR MA</b>	7 714 410 027	Italy	0404	
<b>ZBS30/83S-2MA23S0404</b>	7 714 410 016	Italy	0404	
<b>ZBS30/150S-2MA23S0404</b>	7 714 410 017	Italy	0404	
<b>ZBS30/170S-2SOLARMA23S0404</b>	7 714 410 018	Italy	0404	
<b>ZBS22/120S-2MA23 S6100</b>	7 714 311 012	Latvia	6100	
<b>ZBS30/150S-2MA23 S6100</b>	7 714 311 013	Latvia	6100	
<b>ZBS30/150S-2MA23 S6000</b>	7 714 311 017	Montenegro,Serbia	6000	
<b>TURBO TOWER 30 HRC</b>	7 714 311 035	Netherlands	0700	
<b>TURBO TOWER 30 HRC SOLAR</b>	7 714 311 036	Netherlands	0700	
<b>ZBS16/83S-2MA23S5300</b>	7 714 311 014	Poland	5300	
<b>ZBS16/170S-2SOLARMA23S5300</b>	7 714 410 032	Poland	5300	
<b>ZBS22/120S-2MA23S5300</b>	7 714 311 015	Poland	5300	
<b>ZBS30/150S-2MA23S5300</b>	7 714 311 016	Poland	5300	
<b>ZBS30/150S-2MA23 S7100</b>	7 714 311 020	Ukraine	7100	



**Bosch Thermotechnik GmbH  
D-35576 Wetzlar / Germany**